



## -35A/-40V P-Channel MOSFET

TO-252W(Prefix :D)

### Description

D7R7P40A provides excellent  $R_{DS(on)}$  with low gate charge. It can be used in a variety of applications.

### Features

- $R_{DS(ON)} < 11m\Omega @ V_{GS} = -10V, I_D = -10A$
- Fast switching capability
- 100% Avalanche tested
- 100%  $\Delta V_{DS}$  tested

### Mechanical data

- Case: TO-252W
- Approx Weight: 0.33g ( 0.012oz)
- RoHS compliant
- Case Material: "Green" molding compound, UL flammability classification 94V-0, "Halogen-free".

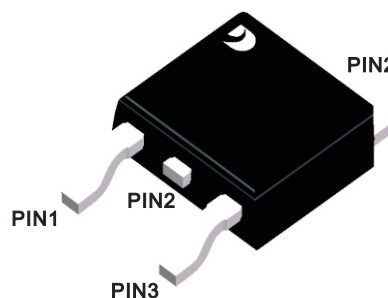

ROHS  
COMPLIANT

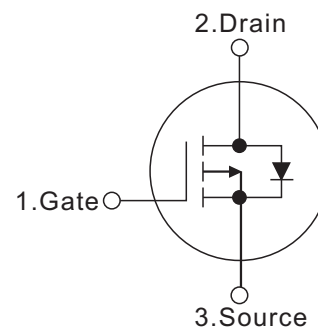

### Absolute Maximum Ratings (Ta=25°C, Unless Otherwise Specified)

Parameter	Symbols	Ratings	Units
Drain-Source Voltage	$V_{DS}$	-40	V
Gate-Source Voltage	$V_{GS}$	$\pm 25$	V
Continuous Drain Current $T_c = 25^\circ C$ $T_c = 100^\circ C$	$I_D$	-35 -27	A
Pulsed Drain Current (Note 2)	$I_{DM}$	-100	A
Avalanche Energy Single Pulsed (Note 3)	$E_{AS}$	800	mJ
Power Dissipation	$P_D$	56	W
Operating junction and storage temperature	$T_J, T_{STG}$	-55 ~ +150	$^\circ C$

#### Notes:

1. Absolute maximum ratings are those values beyond which the device could be permanently damaged.
2. Absolute maximum ratings are stress ratings only and functional device operation is not implied.
3. Repetitive Rating: Pulse width limited by maximum junction temperature.  
 $L = 0.5mH, V_{DD} = 20V, R_G = 25 \Omega, \text{Starting } T_J = 25^\circ C$

### Thermal Resistance

Parameter	Symbols	Ratings	Units
Thermal resistance, junction – case.	$R_{thJC}$	2.2	$^\circ C/W$
Thermal resistance, junction – ambient(min. footprint)	$R_{thJA}$	36	$^\circ C/W$



Electrical Characteristics (Ta=25°C, Unless Otherwise Specified)

Parameter	Symbols	Test Conditions	Min	Typ	Max	Units
<b>Off Characteristics</b>						
Drain-Source Breakdown Voltage	$BV_{DSS}$	$V_{GS}=0V, I_D=-250\mu A$	-40			V
Drain-Source Leakage Current	$I_{DSS}$	$V_{DS}=-40V, V_{GS}=0V$			1	$\mu A$
Gate- Source Leakage Current	Forward	$I_{GSS}$			100	nA
	Reverse				-100	
<b>On Characteristics</b>						
Gate Threshold Voltage	$V_{GS(TH)}$	$V_{DS}=V_{GS}, I_D=-250\mu A$	-1.0		-2.5	V
Static Drain-Source On-State Resistance	$R_{DS(ON)}$	$V_{GS}=-10V, I_D=-10A$		7.7	11	m $\Omega$
		$V_{GS}=-4.5V, I_D=-10A$		9.5	15	
Transconductance	$g_{fs}$	$V_{DS}=-5V, I_D=-10A$		27		S
<b>Dynamic Characteristics</b>						
Input Capacitance	$C_{ISS}$	$V_{DS}=-25V,$ $V_{GS}=0V,$ $f=1.0MHz$		8000		pF
Output Capacitance	$C_{OSS}$			426		pF
Reverse Transfer Capacitance	$C_{RSS}$			400		pF
Gate resistance	$R_G$	$V_{DS}=0V, FREQ=1.00MHz$		8		$\Omega$
<b>Switching Characteristics</b>						
Total Gate Charge (Note 1)	$Q_G$	$V_{DS}=-20V, V_{GS}=-5V,$ $I_D=-10A$ (NOTE1,2)		47.5		nC
Gate-Source Charge	$Q_{GS}$			14.2		nC
Gate-Drain Charge	$Q_{GD}$			13.5		nC
Turn-On Delay Time (Note 1)	$t_{D(ON)}$	$V_{DS}=-20V, V_{GS}=-10V,$ $I_D=-1A, R_G=6\Omega$ (NOTE1,2)		13.2		ns
Turn-On Rise Time	$t_R$			10		ns
Turn-Off Delay Time	$t_{D(OFF)}$			302.7		ns
Turn-Off Fall Time	$t_F$			137.9		ns
<b>Drain-Source Diode Characteristics And Maximum Ratings</b>						
Maximum Body-Diode Continuous Current	$I_S$				-35	A
Drain-Source Diode Forward Voltage (Note 1)	$V_{SD}$	$I_S=-20A, V_{GS}=0V$			-1.2	V
Reverse Recovery Time (Note 1)	$t_{rr}$	$I_F=-10A$		105		ns
Reverse Recovery Charge	$Q_{rr}$	$di/dt=100A/\mu s$		0.45		nC

Notes:

1. Pulse Test: Pulse width  $\leq 300\mu s$ , Duty cycle  $\leq 2\%$ .
2. Essentially independent of operating temperature.



### Test Circuits and waveforms

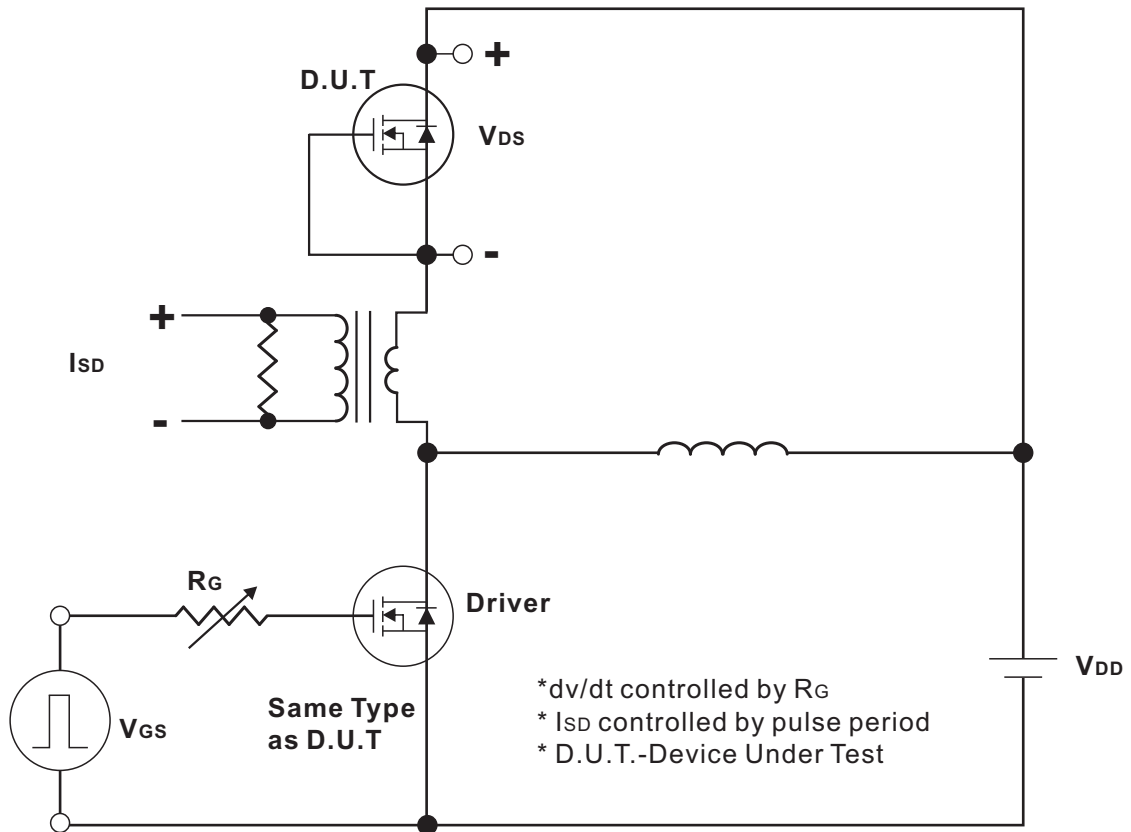

Peak Diode Recovery dv/dt Test Circuit

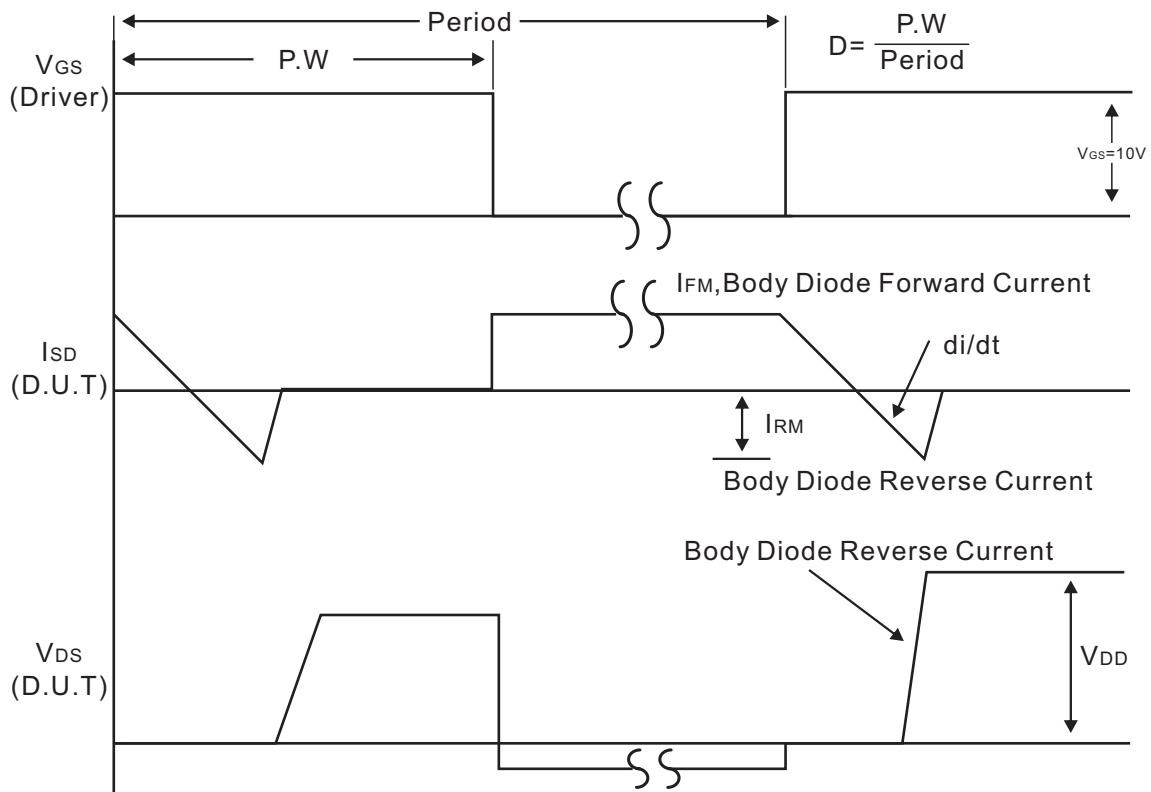

Peak Diode Recovery dv/dt Waveforms



Test Circuits and waveforms

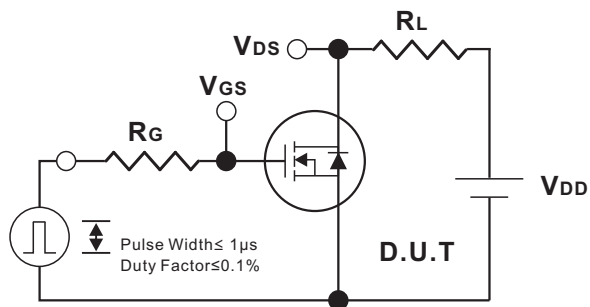

Switching Test Circuit

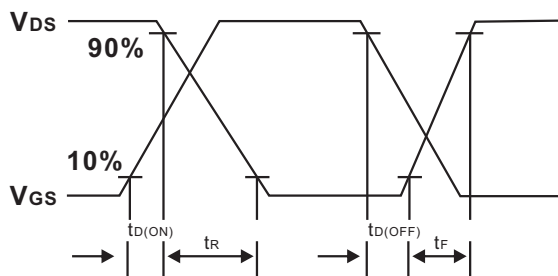

Switching Waveforms

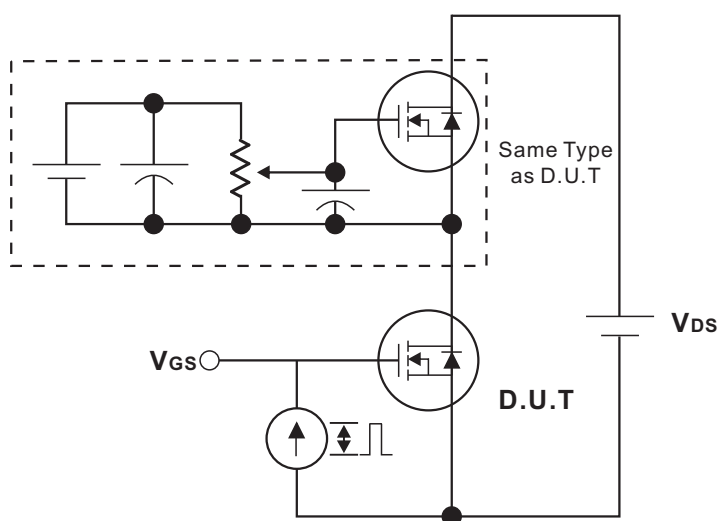

Gate Charge Test Circuit

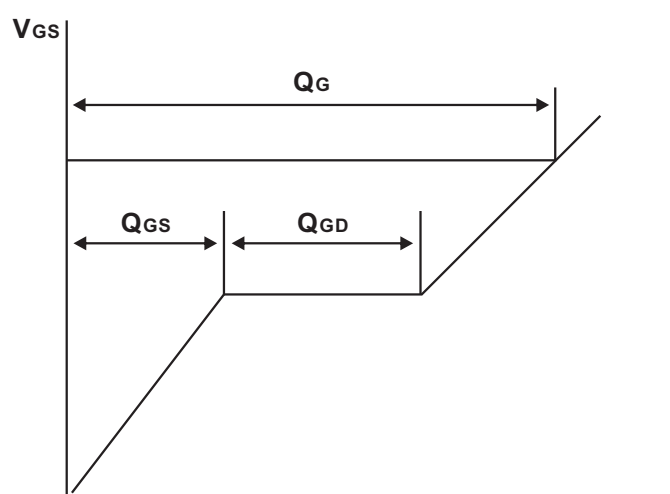

Charge  
Gate Charge Waveform

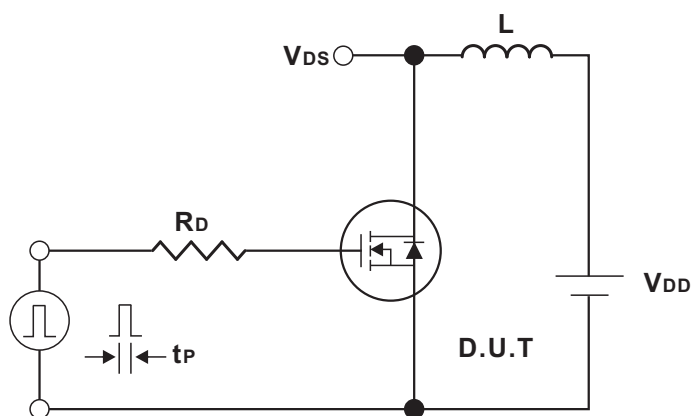

Unclamped Inductive Switching Test Circuit

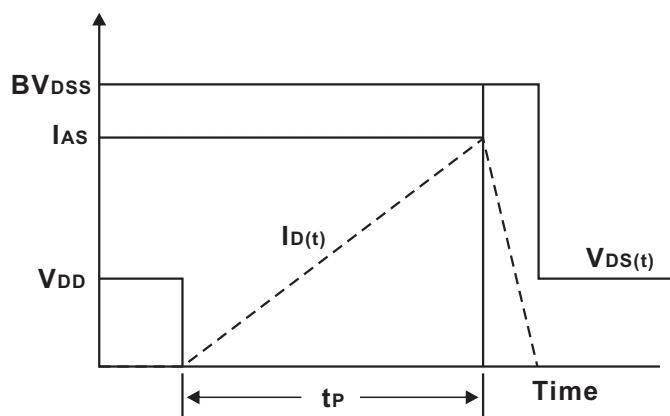

Unclamped Inductive Switching Waveforms



## Typical Characteristics

Fig.1 Output Characteristics

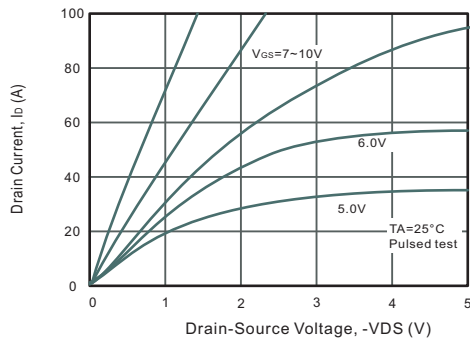

Fig.2 Power Dissipation

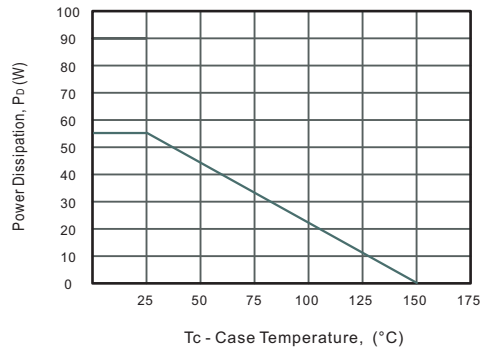

Fig.3 Drain Current Derating

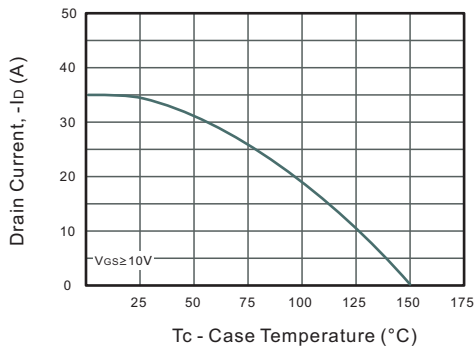

Fig.4 Drain-Source On-Resistance vs. Drain Current

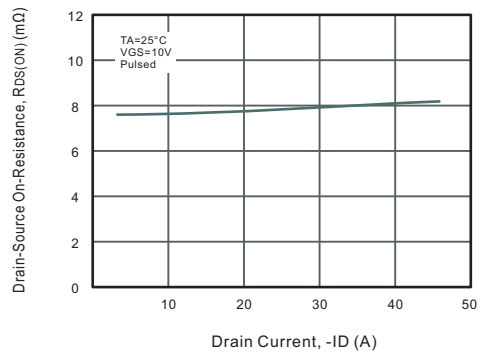

Fig.5 Gate Threshold Voltage vs. Junction Temperature

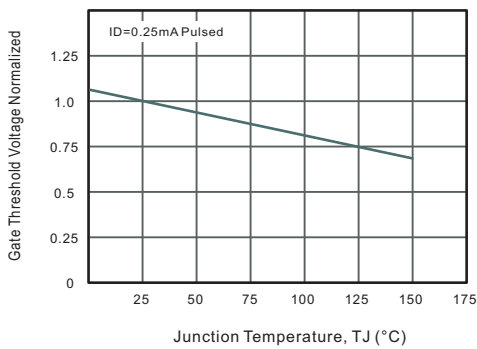

Fig.6 Body-diode Forward Characteristics

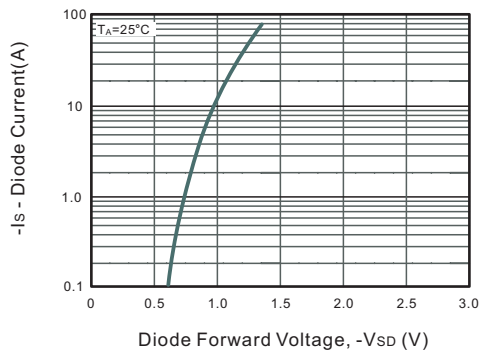

Fig.7 Drain-Source On-Resistance vs. Junction Temperature

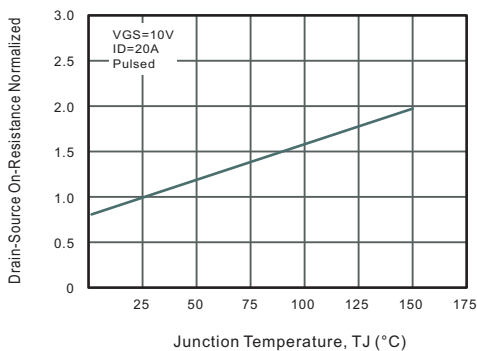
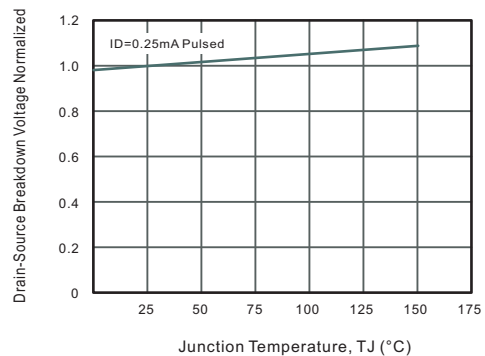

Fig.8 Breakdown Voltage vs. Junction Temperature





### Typical Characteristics

Fig.9 Capacitance Characteristics

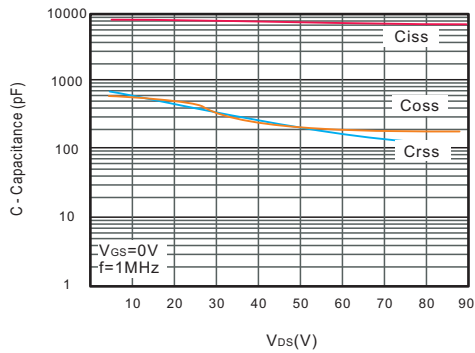

Fig.10 Gate Charge Characteristics

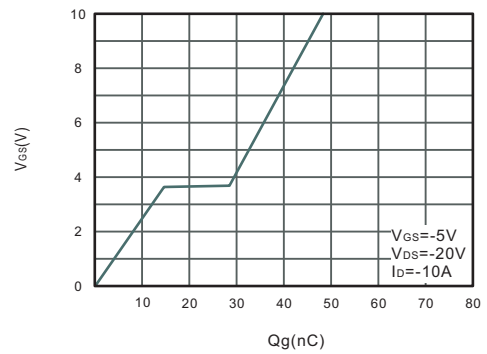

Fig.11 Safe Operating Area

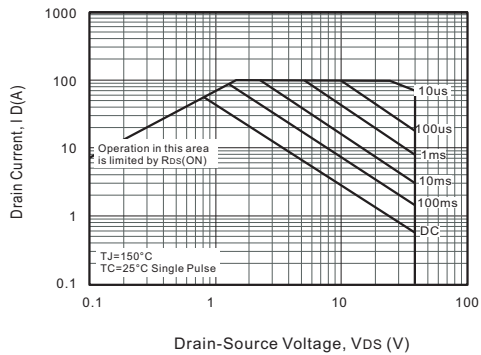
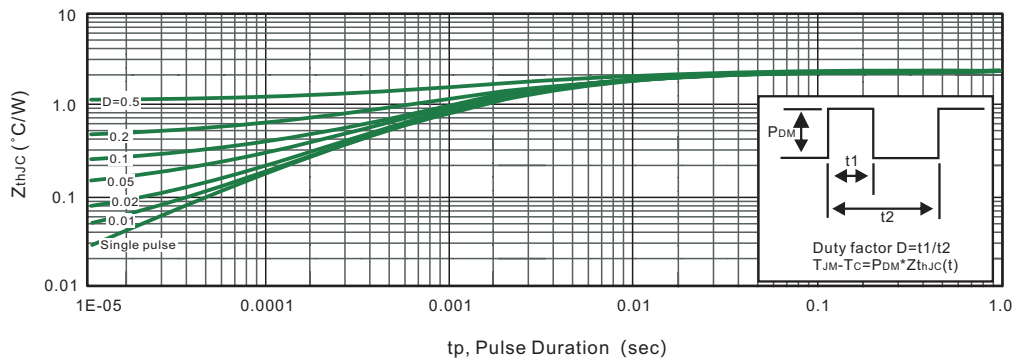
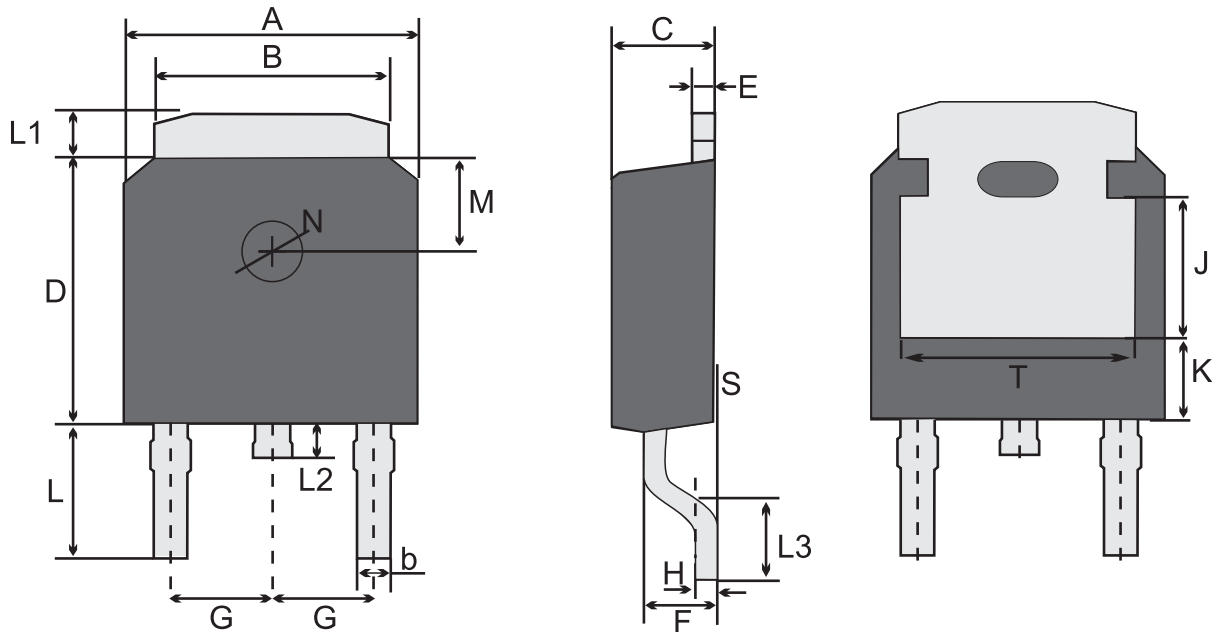

Fig.12 Max. Transient Thermal Impedance





TO-252W(D-PAK) Package Outline Dimensions



TO-252W(D-PAK) Mechanical data

UNIT		A	B	b	C	D	E	F	G	H	L	L1	L2	L3	S	M	N	J	T	K
mm	max	6.7	5.53	0.86	2.5	6.3	0.61	1.87	2.3 typ.	0.55	3.1	1.2	1.0	1.90	0.1	1.8 typ.	1.3 typ.	3.2 ref.	5.23 ref.	1.8 ref.
	typ	6.6	5.33	0.76	2.3	6.1	0.51	1.57		0.50	2.95	1.0	0.8	1.45	0.05					
	min	6.3	5.13	0.66	2.1	5.9	0.41	1.27		0.45	2.7	0.8	0.6	1.00	/					
mil	max	264	218	34	98	248	24	74	91 typ.	22	121	47	39	75	3.9	71 typ.	51 typ.	126 ref.	206 ref.	71 ref.
	typ	260	210	30	91	240	20	62		20	116	39	31	57	2					
	min	248	202	26	83	232	16	50		18	106	31	24	39	/					

Marking

Type number	Marking code
D7R7P40A	D7R7P40A

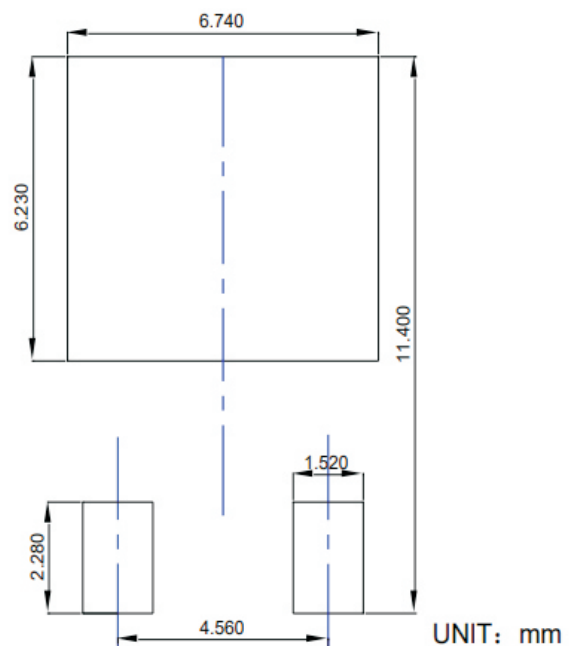

SUGGESTED SOLDER PAD LAYOUT



Important Notice and Disclaimer

Jingdao Microelectronics reserves the right to make changes to this document and its products and specifications at any without notice.

Customers should obtain and confirm the latest product information and specifications before final, purchase or use.

Jingdao Microelectronics makes no warranty, representation or guarantee regarding the suitability of its products for any particular purpose, not does Jingdao Microelectronics assume any liability for application assistance or customer product design.

Jingdao Microelectronics does not warrant or accept any liability with products which are purchased or used for any unintended or unauthorized application.

No license is granted by implication or otherwise under any intellectual property rights of Jingdao Microelectronics.

Jingdao Microelectronics products are not authorized for use as critical components in life support devices or systems without express written approval of Jingdao Microelectronics.